

SA100 HEAVY DUTY  
ADJUSTABLE BRACKET

SA100 HEAVY DUTY  
FIXED BRACKET

1"x1"x1" ALUMINUM  
CHANNEL "PICTURE  
FRAME"

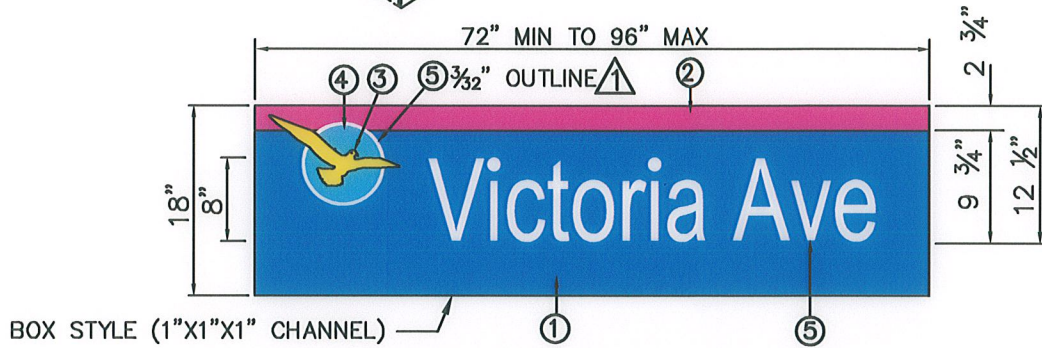
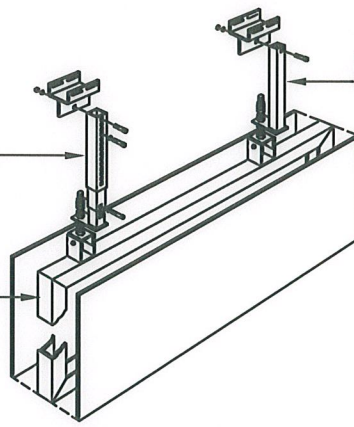

**OVERHEAD STREET NAME SIGN**

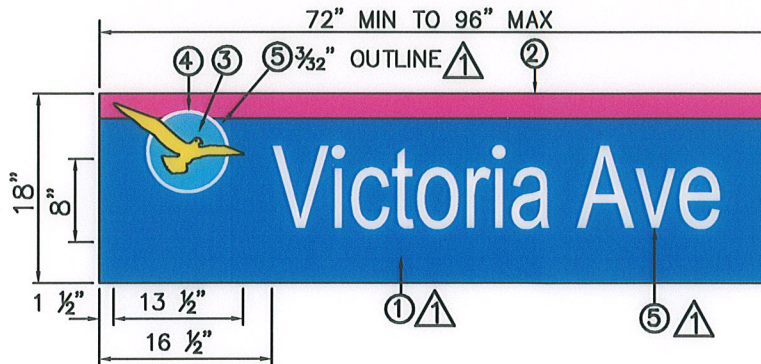

**ADVANCE STREET NAME SIGN**

**COLOR SCHEDULE**

NO.	COLOR NO.	COLOR NAME	FINISH
①	PMS 653c	BLUE	3M TRANSPARENT INK
②	PMS 248c	VIOLET	3M TRANSPARENT INK
③	PMS 128c	YELLOW	3M TRANSPARENT INK
④	PMS 284c	LT. BLUE	3M TRANSPARENT INK
⑤	3M DIAMOND GRADE CUBE REFLECTIVE 4090 WHITE SHEETING		

- SURFACE SHALL BE COVERED WITH 3M DIAMOND GRADE CUBE REFLECTIVE 4090 SHEETING WITH COLORS SCREENED PRINTED AND APPLY 1160A PROTECTIVE OVERLAY FILM FOR A MATCHED COMPONENT SYSTEM WARRANTY.
- TEXT SHALL BE FHWA SERIES C FRUTIGER WITH 8" UPPERCASE AND 6" LOWERCASE LETTERING.
- LOGO SHALL BE PLACED ON THE LEFT SIDE OF EACH SIGN FACE.
- ALL SIGNS SHALL BE ORDERED FROM THE CITY OF OXNARD.

REV.	APPR. BY	DATE

REV.	APPR. BY	DATE
	Robert Hearne	6/21/16



**OVERHEAD & ADVANCE STREET NAME SIGN**

DRAWN: C. GIRON      CKD.: A. WITHANAGE

Department of Public Works

APPR. *R. Hearne*  
ROBERT HEARNE, PE

STANDARD PLAN  
2002

PLATE 206

SHEET 1 OF 1