

REV.	APPR. BY	DATE

REV.	APPR. BY	DATE

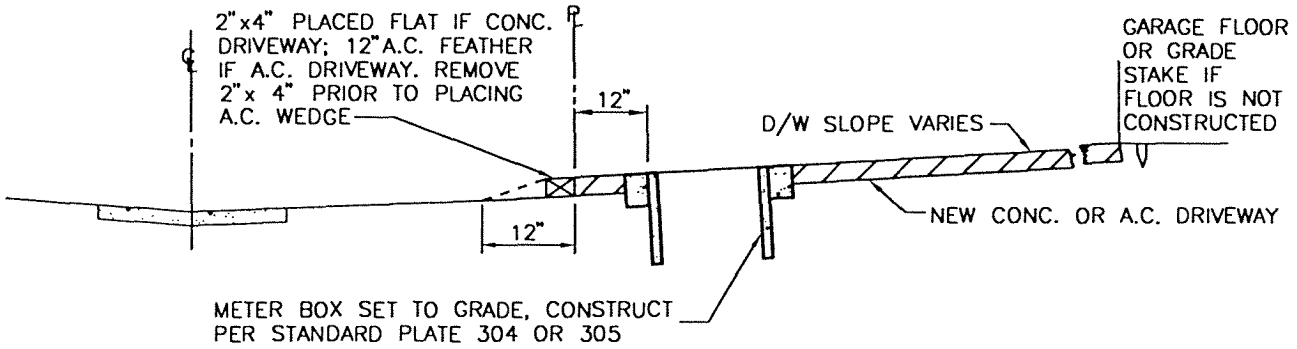
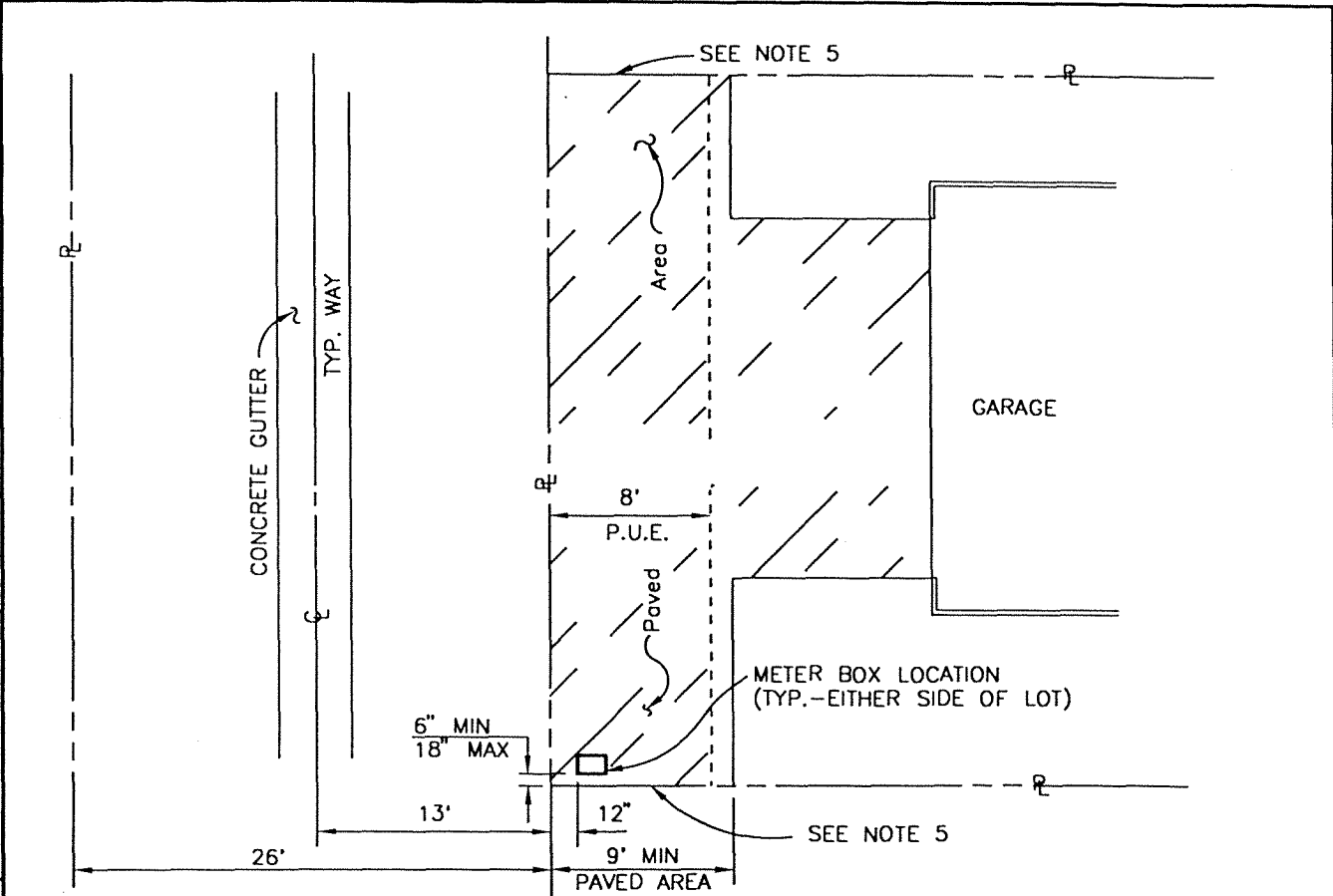

NOTES:

1. ALL METER BOXES SHALL HAVE TRAFFIC COVERS.
2. PRIOR TO PAVING DRIVEWAY, CALL P.W. INSPECTOR TO CHECK INSTALLATION.
3. FOR MULTIPLE DWELLINGS, LOCATION OF METER BOX(ES) MAY VARY WITH LANDSCAPE PLANTERS. MULTIPLE METER SHALL BE GROUPED TOGETHER OR MANIFOLDED PER PLATE 319.
4. PLANTER CURBS REQUIRED FOR ALL PLANTERS ADJACENT TO WAYS.
5. MATCH EXISTING DRIVEWAY OR STRAIGHT GRADE TO EXISTING GRADE OF ADJACENT LOT.



CITY OF

METER BOX INSTALLATION AT BEACH TRACTS

STANDARD PLAN 2002

DRAWN: STAFF CKD.: STAFF
 Department of Public Works

APPR. *Granville M. Bowmon*
 Granville M. Bowmon

PLATE 318

SHEET 1 OF 1