

H	T
0'-8"	8"
8'+	10"

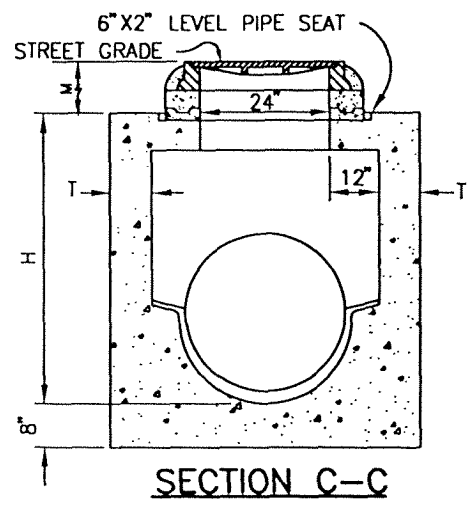

NOTES:

1. HEIGHT H (IN SEC. A-A, B-B, AND C-C) SHALL NOT BE LESS THAN 4'-0", BUT MAY BE INCREASED PROVIDED THAT THE VALUE OF M IS NOT LESS THAN THE MINIMUM SPECIFIED, AND THE REDUCER IS USED. FOR H (IN SEC. C-C) SEE NOTE 4.
2. LENGTH L SHALL BE 4 FEET UNLESS OTHERWISE SHOWN ON THE PLAN. L MAY BE INCREASED OR THE LOCATION OF THE MANHOLE SHIFTED TO MEET THE PIPE ENDS.
3. MANHOLE SHAFT SHALL BE CONSTRUCTED PER SEC. C-C AND DETAIL N WHEN DEPTH M, FROM FINISHED GRADE TO TOP OF BOX, IS LESS THAN 36".
4. DEPTH M MAY BE REDUCED TO AN ABSOLUTE MINIMUM OF 6" WHEN LARGER VALUES OF M WOULD REDUCE H (IN SEC. C-C) TO 3'-6" OR LESS.
5. CRADLE OF MANHOLE SHALL BE POURED IN ONE CONTINUOUS OPERATION EXCEPT THAT A CONSTRUCTION JOINT WITH A LONGITUDINAL KEYWAY MAY BE PLACED AT THE SPRING LINE.

REV.	APPR. BY	DATE

REV.	APPR. BY	DATE

	MANHOLE NO. 1 (MAIN LINE 42" OR SMALLER)		STANDARD PLAN 2002
	DRAWN: STAFF	CKD.: STAFF <i>B</i>	APPR. <i>Granville M. Bowmon</i> Granville M. Bowmon
Department of Public Works			SHEET 1 OF 1