

PLAN
(RINGS AND COVER NOT SHOWN)

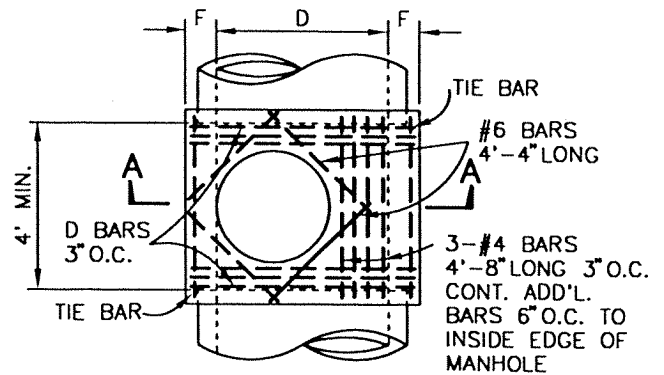

PLAN
(SHAFT NOT SHOWN)

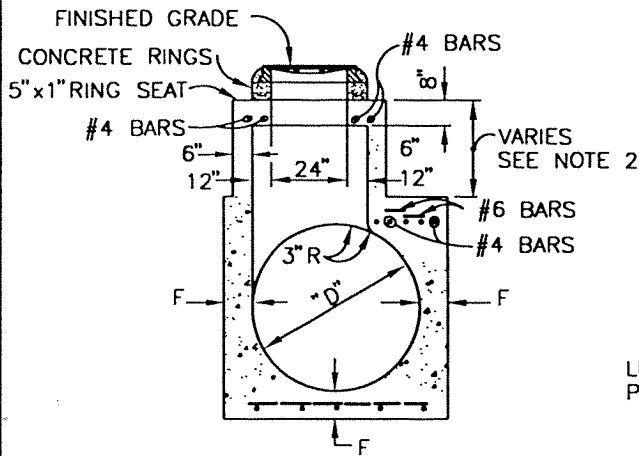

DETAIL M
(SEE NOTE 2)

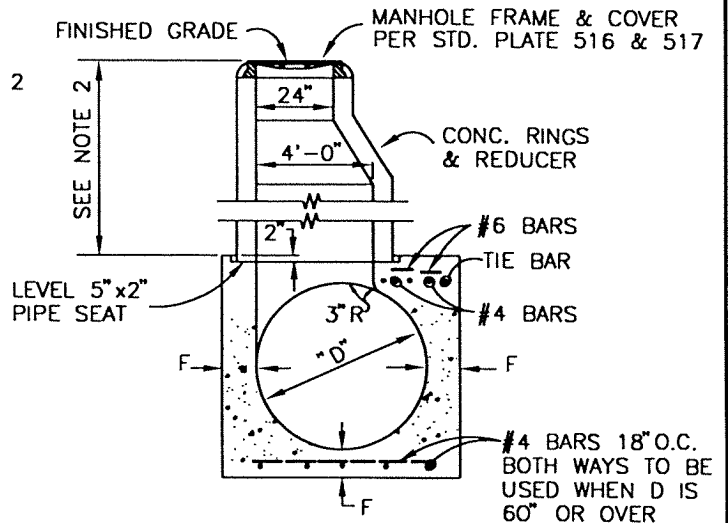

SECTION A-A

NOTES:

1. D BARS SHALL BE #5 FOR D=48" TO 84" INCLUSIVE AND #6 FOR D=90" OR OVER. TIE BARS SHALL BE #3 BARS.
2. DETAIL M: WHEN DEPTH OF MANHOLE FROM FINISHED GRADE TO TOP OF BOX IS LESS THAN 36" CONSTRUCT MONOLITHIC SHAFT AS PER DETAIL M. SHAFT FOR ANY DEPTH OF MANHOLE MAYBE CONSTRUCTED AS PER DETAIL M.
3. REINFORCING STEEL TO BE 2" CLEAR FROM FACE OF CONCRETE UNLESS OTHERWISE SPECIFIED.
4. RINGS, REDUCER AND PIPE FOR ACCESS SHAFT SHALL BE SEATED IN MORTAR AND NEATLY POINTED OR WIPED INSIDE THE SHAFT.
5. CRADLE OF MANHOLE SHALL BE POURED IN ONE CONTINUOUS OPERATION, EXCEPT THAT A CONSTRUCTION JOINT WITH A LONGITUDINAL KEYWAY MAYBE PLACED AT THE SPRING LINE.

TABLE OF VALUES FOR 'F'

D	F
48"	8"
51" & 54"	9"
57", 60", 63", 66"	10"
69" & 72"	11"
78", 84", 90", 96"	14"
102", 108", 114"	16"
120", 126", 132", 138", 144"	18"

REV.	DATE

REV.	DATE



CITY OF

MANHOLE No. 2
(MAIN LINE 45" OR LARGER)

STANDARD PLAN
2002

DRAWN: STAFF

CKD.: STAFF LB

PLATE 514

Department of Public Works

APPR.

Granville M. Bowman

SHEET 1 OF 1