

PLAN VIEW
(4 YARD)

FRONT VIEW

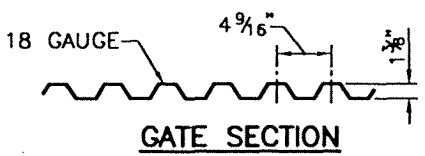

GATE SECTION

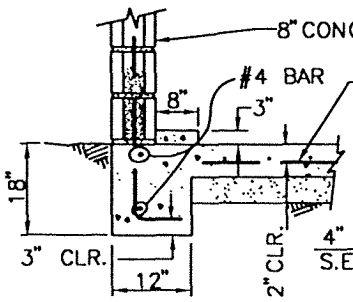

FOOTING SECTION

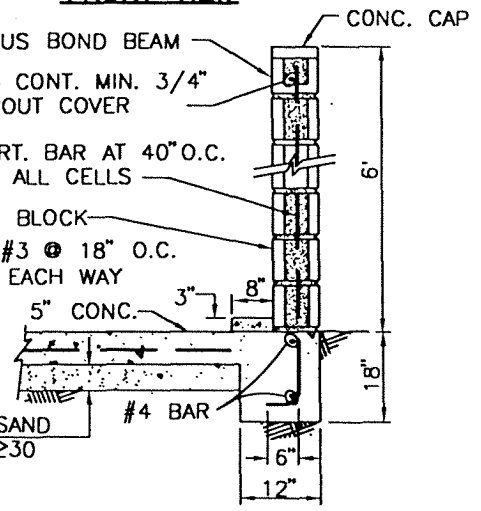

ALTERNATE FOOTING

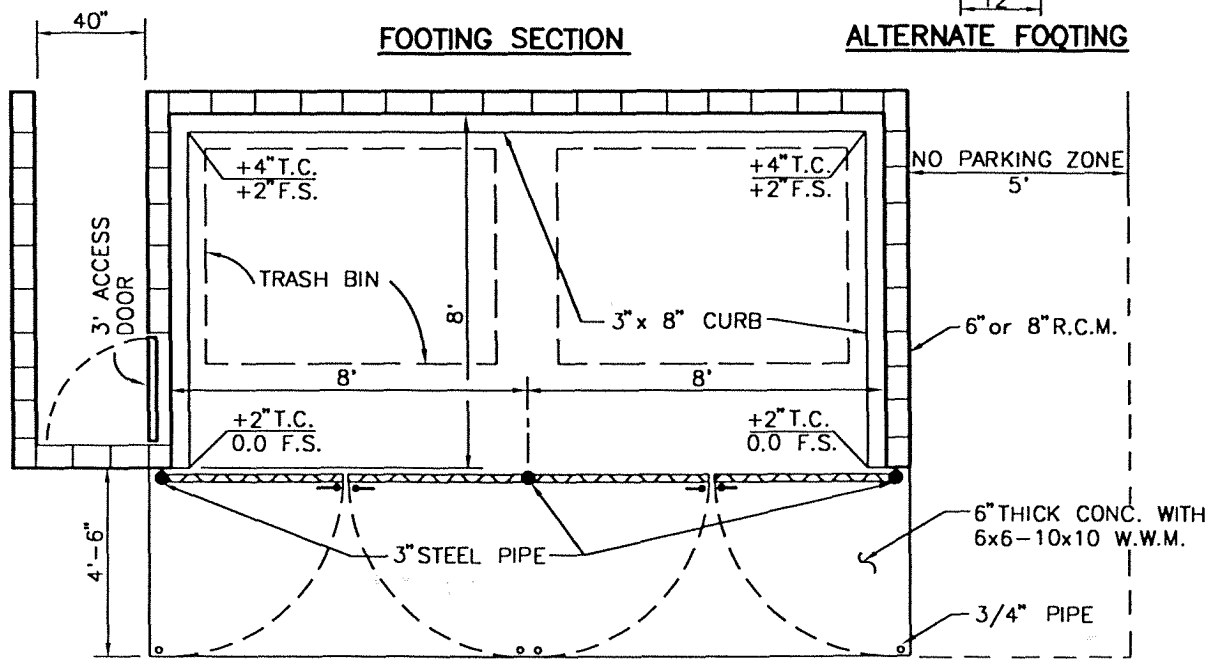

PLAN VIEW
(DOUBLE 4 YARD)

REV.	APPR. BY	DATE

REV.	APPR. BY	DATE

<p>CITY OF Oxnard</p>	<p>PARALLEL REFUSE CONTAINER ENCLOSURE WITH SIDE ENTRANCE</p>		<p>STANDARD PLAN 2002</p>
	<p>DRAWN: STAFF</p>	<p>CKD.: STAFF</p>	<p>APPR. <i>Granville M. Bowman</i></p>
<p>Department of Public Works</p>			<p>SHEET 1 OF 2</p>

NOTES:

1. WALLS: SLUMPSTONE BLOCK, REINFORCED AND CAPPED. STRUCTURE TO BE APPROVED PRIOR TO CONSTRUCTION BY BUILDING AND SAFETY DEPARTMENT.
2. GATES: SHALL BE STEEL FRAMED WITH STEEL ANGLE BRACE TYPE METAL 18 GAUGE AND STEEL MINI V-BEAM PANEL AND THE GATE ITSELF, SHALL BE HUNG ON A 3" STEEL PIPE, CONCRETE FILLED THAT IS NOT ATTACHED TO THE ENCLOSURE. SHALL NOT OPEN INTO DRIVING LANES OR PARKING SPACES.
3. SIZE: ENCLOSURE SIZE FOR SINGLE FOUR YARD CONTAINER IS TO BE 8' DEEP AND 8' WIDE AND FOR DOUBLE FOUR YARD IS TO BE 8' DEEP AND 16' WIDE. SIZE OF ENCLOSURE TO BE DETERMINED IN ADVANCE OF CONSTRUCTION BY THE REFUSE SUPERINTENDENT.
4. LOCATION: TO BE DETERMINED IN ADVANCE OF CONSTRUCTION FROM PLANS SUBMITTED TO THE REFUSE SUPERINTENDENT. CONSTRUCTION SHALL BE IN ACCORDANCE WITH CITY OF OXNARD ORDINANCE--SECTION 34-9.4, 15-19, AND 15-26.
5. FLOOR: SHALL BE OF CONCRETE, WITH A MAXIMUM SLOPE OF 2" TO DRAIN ENCLOSURE, AND FLUSH WITH ADJOINING PAVEMENT
6. LATCH: A LATCHING ASSEMBLY IS REQUIRED WITH CANE BOLTS ON BOTH GATES TO HOLD IN OPEN AND CLOSED POSITION WITH 3/4" PIPE TO HOLD THE CANE BOLT.
7. ACCESSABILITY: ENCLOSURE LOCATIONS SHOULD NOT BE BEHIND ANY LOCKED GATES, CHAINS, OR FENCES. IF ENCLOSURE LOCATIONS ARE SITUATED BEHIND LOCKED COMPLEXES, THE CONDITIONS FOR PICKUP WILL BE FORMALIZED IN A WRITTEN AGREEMENT SIGNED BY THE OWNER AND APPROVED BY THE REFUSE SUPERINTENDENT. THIS AGREEMENT MUST BE APPROVED PRIOR TO APPROVAL OF PLANS. CONTACT THE REFUSE PROGRAM FOR DETAILS AT 385-8060.
8. ROOF: A SOLID ROOF WITH 8 FEET OF CLEARANCE IS REQUIRED ON ALL TRASH ENCLOSURES.
9. GREASE INTERCEPTOR: TRASH ENCLOSURES SERVING FOOD PREPARATION FACILITIES, GAS STATIONS AND GROCERY STORES SHALL INCLUDE A TRAFFIC RATED TRENCH DRAIN WITHIN THE ENCLOSURE WHICH DRAINS THROUGH A GREASE INTERCEPTER TO THE SEWER SYSTEM. OTHER USES MAY BE REQUIRED TO INSTALL A TRENCH DRAIN AS DIRECTED BY THE CITY ENGINEER.
10. FIRE SPRINKLER: FIRE SPRINKLER MAY BE REQUIRED BY THE CALIFORNIA BUILDING CODE OR THE THE UNIFORM FIRE CODE.
11. PARKING: NO PARKING SPACES ARE ALLOWED WITHIN 5 FEET OF EDGE OF ENCLOSURE.

REV.	APPR. BY	DATE

REV.	APPR. BY	DATE

 <p>CITY OF Oxnard Department of Public Works</p>	PARALLEL REFUSE CONTAINER ENCLOSURE WITH SIDE ENTRANCE		STANDARD PLAN 2002 PLATE 604
	DRAWN: STAFF CKD.: STAFF <i>LB</i>	APPR. <i>Granville M. Bowman</i> Granville M. Bowman	SHEET 2 OF 2